

Journal of Educational Research & Social Sciences Review (JERSSR)

Development and Validation of a Nano Learning Practices Scale (NLPS)

- | | |
|--------------------------------------|---|
| 1. Zunaira Kanwal | PhD Scholar, Institute of Education and Research, University of the Punjab, Lahore, Pakistan Email: zunairakanwal75@gmail.com |
| 2. Dr. Muhammad Shahid Farooq | Professor, Chairman of the Department of Advanced Studies in Education, Institute of Education and Research, University of the Punjab, Lahore, Pakistan Email: shahid.ier@pu.edu.pk |



Abstract

The study aimed to develop and administer a Likert-type instrument related to the implications of nano learning practices for content delivery at the higher education level. The scale, named "Nano Learning Practices" (NLP), was developed after a review of the literature. Initially, total 27 items were developed. After the review, the experts' observations were incorporated into the instrument. A total of 25 items were finalized for scale administration. The study employed a descriptive approach, utilized a quantitative method to collect data. Data were collected from a purposively selected sample of 203 undergraduate students from public and private universities in Punjab. Exploratory Factor Analysis (EFA) was used to identify factors. As a result of the analysis, five factors with good factor loadings were identified. These factors were setting objectives (1-5 items), Chunking Information (5-10 items), Effective Assessment (11-13 items), incorporating visuals and multimedia (14-20), and Timely Feedback (21-25 items). Then, Confirmatory Factor Analysis (CFA) was applied to confirm these factors. Overall values for Cronbach's Alpha of the instrument were 0.878. The values for Average Variance Extracted (AVE), construct reliability (CR), and discriminant validity (DV) were found within the acceptable range. The developed instrument for nano learning practices was found to be reliable and valid. The Nano-Learning Practices Scale (NLPS) is an instrumental assessment tool for evaluating nano-learning methodologies in academic settings. It may equip educators with insights to strategically plan lessons, aiming to optimize learning and sustain student attention. The NLPS may significantly contribute to educational research by designing clear and concise learning objectives, integrating chunked information, the inclusion of effective assessment, incorporating visuals and multimedia, and giving timely feedback. This scale may serve as a reliable resource for future academic investigations, focusing on enhancing the accessibility and effectiveness of student learning.

Keywords: Learning, Nano Learning, Instrument Development.

Introduction

In today's digital world, students have less attention span to spend extended time in classrooms and to attend long hours of lectures. The excessive availability of digital devices and constant excess of internet is causing distraction, which is increasing day by day. Several studies suggested that the focus maintenance of the human brain on a lesson is just 10 to 15 minutes, and its maximum is around 45 minutes. The human mind requires time for reflection and to process the perceived information. Several educators have different narratives regarding the impact of a digitized environment. They believe that continuous sensory overload reduces our attention span and the ability to absorb new information. Some researchers believe that this environment enhances our capacity to retain and remember more data, particularly when information is divided into smaller bits or more organized blocks. Another perspective is that breaking information into chunks is more effective for learning and more likely to apply that learned content (Hudovernik, 2021).

Nanotechnology offers various exciting applications for daily use as we move towards the subsequent stages of the 21st century (Baughman et al., 2023). This advancement brings a revolution in the field of education where a learner is not dependent on the direct involvement of an instructor for learning new content. Instead, learners can have brief instructional sessions and can get information whenever and wherever they need it. These lessons are delivered through multiple platforms like Twitter, TikTok, YouTube, and text messages. Each lesson targets to learn a single

concept at a time to address the need to learn something instantly. Most of the lessons are even paradoxically interactive. These designed lessons may or may not fulfil the learning needs, but they may also build connections to the in-depth learning of the content for the learners if anyone desires to learn in detail related to the concept. The teacher can use these lessons as per the need. They can utilize it as an independent plan for teaching the set target, or they can use it as supplementary material to enhance the comprehensive understanding of the students.

Theoretical framework

The idea of cognitive load theory posits that the capacity of the working memory is limited, so that if a learning task exceeds this capacity, it will hamper the learning process. Cognitive load theory (CLT) focuses on the structure of learning instructions in a way that doesn't exceed the limit of working memory, to ensure effective and meaningful learning. It provides logical justification for nano learning, reduction in intrinsic cognitive load (ICL) and extraneous cognitive load (ECL) leads to better retention of learned material and makes independent learners. Cognitive load theory sees the subsequent automation and development of schemas as the primary objective of learning (Sweller et al. 1998). The process of construction of these schemas involves activities such as interpretation, exemplification, classification, inference, differentiation, and organization (Mayer 2002). The process of schema construction imposes a specific load known as germane cognitive load. Instructional methods should be designed to guide and stimulate students to engage in automation and schema construction, thereby increasing germane cognitive load. In this perspective, NL promotes higher-order learning, in both ways: It helps to lessen the difficulty level of the planned task and complexity to make it understandable for the age groups (Merriënboer & Sweller, 2005).

Existing Measures

The latest academic literature reveals a significant scarcity of research work, particularly in the field of nano learning. There is no standardized tool for measurement and validation of conceptual aspects, particularly related to nano learning, yet. The development of a reliable scale to assess the practical implications of nano learning practices among undergraduate students is an essential step to bridge the gaps in educational research and related to its application. The measurement tool of nano learning practices would provide valuable insights, which may be helpful for policymakers to bring change for the effective implementation of these practices at the Higher Education Level. However, the relative absence of valid instruments represents a considerable impediment to further progress in the significant areas of education. Therefore, we considered that the development and validation of a valid and reliable instrument is needed for the broader field of nano learning. Hence, this study aimed to design and validate an instrument for measuring nano learning practices in a higher education setting.

Problem Statement

This study planned to bridge the literature gap. After a detailed literature review, there is no valid and reliable instrument has been found to identify the existence of nano learning practices at a higher level. The purpose of the current study is to develop an instrument to measure the nano learning practices at the higher education level.

Objective of the Study

The objective of this study is

- I. To develop and validate a scale to measure the nano learning practices at higher Education Level.

Significance of the Study

This study may be an addition to the existing literature on nano learning and provide insights for teachers, university administrators, and policymakers concerned with understanding its impact on learners' learning. It may be helpful for the higher educational concerned administrative bodies who are interested in implementing nano learning practices at this level. It may facilitate instructors to disseminate content in the form of small chunks after making it more understandable for the learners.

Research Question

1. How to develop and validate a scale to measure the nano learning practices at higher Education Level.

Literature Review

In the age of digitization, the concept of nano learning draws the attention of both students and teachers. As teachers are facing a number of challenges related to delivering large content in a limited

time while maintaining the students' attention, managing overcrowded classes, and addressing the problem of students' burnout, not interested in seeking help when needed, and a lack of motivation to learn. Nano learning addresses these challenges by providing a number of solutions. It is popular among Generation X and Generation Z because they grew up with digital technology. This approach provides fast and entertaining information in a way that holds their attention while delivering the information they learn (Marks, 2021).

Nano learning enhances the learner's productivity because they learn through the fast absorption of information. As mentioned earlier, traditional approaches for learning required long hours of learners' stay in classes for learning, but nano learning requires less time to learn more content (Aburizaizah & Albaiz, 2021). This results in helping students to stay attentive while learning the entire lesson from start to end. Consequently, this increases the ability to receive and retain more information (Gramming et al., 2019).

Nano learning offers multiple ways for additional gain that remarkably enhance the experience of learning. The learners can break their set learning objectives into small, learnable segments in a set timeframe and are not overwhelming, which results in to increase in the productivity of learners' learning. Moreover, nano learning decreases the screen time of the learners. Since the emergence of the coronavirus, learners and teachers shifted to online mode, which automatically increased their screen time. The traditional approach of learning online demands that students spend at least eight hours on the screen, which can potentially affect their health (Railean, 2017). Nano learning requires less screen time to learn the content. Additionally, nano learning appeals to the learners because it helps to increase the learner's concentration span. Generally, nano learning presents information in the form of chunks such as illustrations, infographics, animations, and videos (Kävrestad & Nohlberg, 2019). These ways of learning are more interactive than static text. Subsequently, digital platforms like TikTok and Twitter are more common among Generation Z and millennials, which is why nano learning is more exciting for students and makes them more eager to learn their lessons through these platforms.

Nano learning offers incredible advantages; teachers should understand the preferences of the students to make its implementation more helpful. Teachers should start by knowing the learners' specific needs and their preferences, and which type of content they find most effective for learning. For example, some learners prefer instructional TikTok videos for learning, and others may prefer to learn better through slides. Educators must try to provide a range of nano learning materials to truly cater to the students' learning needs (Cabrero & Román, 2018).

Nano Learning Practices

The success of nano learning hinges on five critical components: Clear and concise learning objectives, Chunking information, Effective assessment, Incorporation of interactive elements, and Timely feedback. Each element plays a pivotal role in ensuring that nano learning modules are not only accessible but also impactful, fostering enhanced retention and application of knowledge.

- i. Clear and Concise Learning Objectives
- ii. Chunking Information
- iii. Effective Assessment
- iv. Incorporation of Visuals and Multimedia
- v. Timely Feedback (Sukmojati, et al., 2025).

Methodology

The nature of the study was quantitative. A causal comparative study design was used for this research work. This design is employed when the formation of groups has already happened before proceeding with the study (Bakker & van Eerde, 2015; McCusker & Gunaydin, 2015).

The development of the instrument for assessing nano learning practices comprises various stages. The process of instrument development began with an in-depth review of the related literature and discussions with experts in the field of education, and essential factors related to nano learning practices were identified. Items were developed related to these factors and reviewed by experts, which led to modifications and refinement of the items. The revised instrument was administered in the field, and the resulting data underwent reliability, exploratory, and confirmatory factor analysis to explore and confirm the items and related factors of the instrument.

After a review of the literature, an initial framework for the instrument development of nano learning practices was designed. The objective of the instrument development was to assess the level

of the students' understanding through the implementation of the nano learning practices as identified in the literature. A set of questions was drafted. The initial version of the questionnaire consisted of 27 items. The experts reviewed the initial draft, and then the suggestions of the experts were incorporated accordingly. The questionnaire was revised with consideration of its relevance to the education field. The revised instrument consisted of 25 items and was used for pilot testing. To conduct the exploratory factor analysis, a questionnaire was administered on a purposively selected sample of 203 university students enrolled in BS Education from public sector universities of Lahore. After initial exploratory factor analysis, confirmatory factor analysis was applied on the sample consisting of 450 undergraduate students enrolled in BS programmes from three public sector universities of the Punjab. Factor analysis was used to indicate the reliability of the items through the values of factor loadings.

The literature argued that at least 50 percent of an indicator's variance should be accounted for by the underlying latent variable (Henseler et al., 2009). Instrument reliability and validity were assessed by using AMOS. Convergent and discriminant validity were measured to strengthen the instrument. Convergent validity was assessed as Average Variance Extracted (AVE). Corrected item-total correlations and Cronbach's alpha if the item deleted were calculated to measure the impact of each item on the overall scale. Overall reliability was measured using the coefficient of Cronbach's alpha. Factor analysis is used to identify construct validity, the potential underlying structure of the data. Principal Component Analysis (PCA) was employed to analyze the correlation matrix. Subsequent recommendations from psychometric literature (Henson & Roberts, 2006), multiple criteria were applied to identify the appropriate number of factors to retain.

Results and Discussion

The instrument was pilot tested and administered on undergraduate university students, and an exploratory factor analysis was performed to explore the factors. Results of the data analysis are discussed below.

Construct Validity: Exploratory Factor Analysis

Initially, data suitability was checked for factor analysis by applying the following analysis.

KMO of Data

Hinton et al., (2004) suggest that a p-value <0.05 endorses a significant relationship between variables, so, KMO values of the data were checked.

Table 1 KMO and Bartlett's Test for Nano Learning Practices

KMO Estimation		
Kaiser-Meyer-Olkin Measure of Sampling Adequacy.	.840	
Bartlett's Test of Sphericity	Approx. Chi-Square	4887.019
	Df	300
	Sig.	.000

The above-presented results confirmed the suitability of the data for factor analysis. The suitability of the data for PCA was checked by a Kaiser–Meyer–Olkin (KMO) measure of sampling adequacy, values were above the recommended threshold of 0.6 (0.840), and results of Bartlett's Test of Sphericity were significant ($p < 0.0005$) (Tabachnick and Fidell, 2007). Particularly, Bartlett's Test of Sphericity found an approximate Chi-Square value of 4887.019 ($p < .05$), and the Kaiser-Meyer-Olkin (KMO) measure of sampling adequacy was .840. These values indicate that the data met the above-mentioned set of requirements for conducting the factor analysis. Principal Component Analysis (PCA) was applied to 25 statements.

Factor Loading

The values of the rotated component matrix were used to consider the factor and item adjustments while conducting the factor analysis. Five elements were found through the rotated component matrix. Field (2005) recommended that the items that show cross-loadings on multiple factors were supposed to be considered weak and eliminated. Subsequently, items with a smaller loading than 0.4 across the components were excluded.

Table 2 Rotated Components Matrix for Nano Learning Practices items

Sr. No	Statements	Factors Loading
Incorporate Visuals and Multimedia		
IVM16	My instructor uses diagrams with explanations to make the concept understandable.	.912

Development and Validation of a Nano Learning Practices Scale (NLPS).....Kanwal & Farooq

IVM14	My instructor uses clickable infographics to engage students directly with the content.	.901
IVM17	My instructor incorporates videos to create an engaging learning experience.	.885
IVM20	My instructor uses drop-and-drag activities to engage students with the learning content.	.868
IVM18	My instructor includes animations to simplify the complex information.	.837
IVM15	My instructor uses charts to make lessons easier to understand.	.707
IVM19	My instructor pairs visuals with narrated audio to make the lesson informative.	.497
Timely Feedback		
TF21	My instructor boosts students' confidence through encouraging messages.	.923
TF24	My instructor provides targeted feedback to identify areas that need more attention.	.920
TF23	My instructor uses timely feedback to track students' progress.	.911
TF25	My instructor provides immediate feedback to reinforce learning.	.880
TF22	My instructor provides constructive feedback on mistakes, which helps students to improve.	.757
Chunking Information		
CI9	My instructor delivered information in a sequenced manner.	.857
CI7	My instructor focuses on delivering essential information without unnecessary detail.	.852
CI8	My instructor focuses entirely on understanding one concept before moving on to the next topic.	.850
CI10	My instructor presents content in visually appealing chunks.	.800
CI6	My instructor focuses on breaking down complex information into manageable units.	.792
Learning Objectives		
LO1	My instructor set narrowly focused objectives to achieve a specific outcome.	.896
LO2	My instructor set clearly articulated objectives to achieve a specific outcome.	.884
LO4	My instructor set flexible objectives to address the specific needs of the students.	.783
LO3	My instructor set objectives that are achievable within the set time frame.	.764
LO5	The delivered content in class is aligned with the set objectives.	.732
Effective Assessment		
EA12	My instructor uses quick scenarios that align directly with the learning objectives to assess students' learning.	.853
EA11	My instructor uses interactive quizzes to assess the students' learning.	.787
EA13	My instructor uses assessment to pinpoint areas of difficulty for students.	.761

The grouping of factors done in consideration of the factor loadings, items LO1, LO2, LO3, LO4, and LO5 combined into a single factor, reflects as the “Learning Objectives” element. The second element consisted of items CI6, CI7, CI8, CI9, and CI10, which conceptually linked to the concept of Chunking Information.” The third component grouped items EA11, EA12, and EA13, all of which focused on “Effective Assessment.” The fourth factor, combined as IVM14, IVM15, IVM16, IVM17, IVM18, IVM19, and IVM20 named as Incorporating Visuals and Multimedia. The fifth factor includes TF21, TF22, TF23, TF24, and TF25, labelled as Timely Feedback. Items IVM15 showed loading below 0.40, which is why it was excluded from further analysis and findings. Straub et al. (2004) stated that construct validity is supported when items do not cross-load above 0.40, have individual loadings of at least 0.40, and meet the latent root criterion (eigenvalue ≥ 1). Five factors — Learning Objectives, Chunking Information, Effective Assessment, Incorporating Visuals and

Development and Validation of a Nano Learning Practices Scale (NLPS).....Kanwal & Farooq

Multimedia, and Timely Feedback —were identified for measuring nano learning practices through exploratory factor analysis.

Items Total Correlation

Table 3 Items Total Correlation of Nano Learning Practices Scale

	M	SD	Corrected Item Total Correlation	α if Item Deleted
Clear and Concise Learning Objectives				
LO1	3.62	.88	.310	.877
LO2	3.56	.87	.296	.877
LO3	3.63	.91	.301	.877
LO4	3.53	.85	.316	.877
LO5	3.43	.97	.260	.879
Chunking Information				
CI6	3.73	.88	.241	.879
CI7	3.74	.89	.259	.878
CI8	3.87	.89	.317	.877
CI9	3.64	.92	.220	.879
CI10	3.78	.88	.266	.878
Effective Assessment				
EA11	4.09	1.20	.407	.875
EA12	3.63	1.26	.456	.874
EA13	3.83	1.14	.506	.872
Incorporate Visuals and Multimedia				
IVM14	3.34	.95	.602	.870
IVM15	3.18	1.02	.424	.874
IVM16	3.30	.96	.535	.871
IVM17	3.35	.94	.579	.870
IVM18	3.37	.97	.559	.871
IVM19	4.01	.98	.226	.880
IVM20	3.36	.98	.581	.870
Timely Feedback				
TF21	3.48	.99	.722	.866
TF22	4.04	1.11	.552	.871
TF23	3.54	.99	.657	.868
TF25	3.80	.95	.723	.866
TF24	3.52	1.01	.727	.866

Several measures were used for further evaluation of the individual items' suitability and instrument internal consistency. The correlation matrix revealed that all item-to-item correlations were positive, with a mean value of 0.26, highlighting that the items were consistent without being redundant (Briggs and Cheek, 1986). Subsequently, corrected item-total correlations for most of the items exceeded 0.30, except for LO2, LO5, CI6, CI7, CI8, CI9, CI10, and IVM19, which lie slightly below 0.3. This indicates that overall, the correlation of the items with the total score of the test (Field, 2024). Cronbach's alpha values were also examined, showing that one item below the accepted range were removed, which in turn high the overall Alpha value. Furthermore, means of items and values for standard deviations were calculated. According to Field (2024), items with means 1 or 5 may reduce overall item correlation, which should be removed to improve the performance of the scale.

Cronbach Alpha, Convergent validity (Average Variance Extracted) and Composite Reliability (CR), and Discriminant validity (DV)

Table 4 Cronbach's Alpha, Convergent validity (Average Variance Extracted) and Composite Reliability (CR), and Discriminant validity (DV)

Factors	Number of Items	AVE	CR	DV	A
Learning Objectives	1-5	0.583	0.871	0.764	.916
Chunking Information	6-10	0.601	0.882	0.775	.929
Effective Assessment	11-13	0.662	0.853	0.814	.923
Incorporate Visuals and Multimedia	14-20	0.703	0.932	0.839	.940
Timely Feedback	21-25	0.823	0.958	0.907	.973

The instrument validity and reliability were established by using Average Variance Extracted (AVE), Discriminant Validity (DV), and Composite Reliability (CR). An AVE value greater than 0.50 is considered acceptable for adequate convergent validity, but values between 0.30 and 0.50 may be considered acceptable (Fornell & Larcker, 1981). For accepted reliability values, the values of CR range between 0.70 or higher, indicating good reliability, but the values range between 0.60 and 0.70 may also be acceptable if other construct indicators of validity are strong. Discriminant validity (DV) values were measured by square root calculation of the AVE, which must be greater than the inter-construct correlations for each dimension. Cua et al. (2001) stated that the items considered significant with factor loadings of at least 0.40 for their relevant dimensions. All items except one item in the instrument had loadings above 0.40 and were considered for the final analysis. The measured values of AVE, DV, and CR for each dimension all lie within the acceptable range.

Confirmatory Factor Model

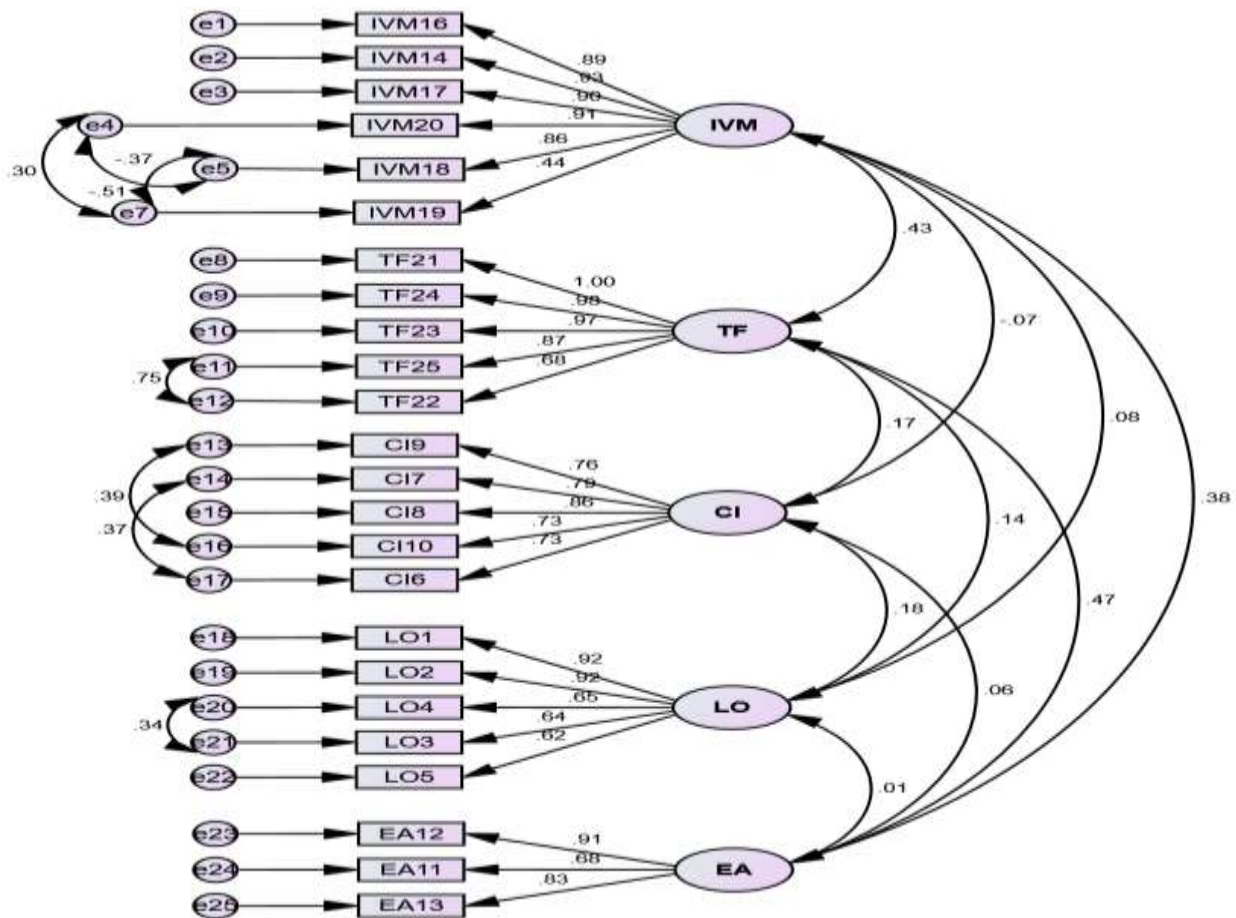

Figure 4.5: Estimations of the standardized path coefficient of the confirmatory factor model.

Model Fitness Index for Nano Learning Practices showed that the Model is fit with factor values. The CMIN=401.255, Df 235 indicates a Chi-square/df=1.707, which meets the condition for a good fit model. The GFI=.861, AGFI=.823, and both values for CFI=0.964 and TLI= .958 are greater than 0.90, and the value for RMSEA=0.059 is less than 0.08. The model significance p-value= 0.065, showing that it has high significance. The one item IVM15 deleted and covariates drawn between the error terms e5 to e4, e7 to e4, e7 to e5 of factor Incorporate Visuals and Multimedia. Covariate drawn between the error terms e12 to e11 of factor Timely Feedback. Covariates related to factor chunking information drawn between the error terms e16 to e13 and e17 to e14. The deletion of one item and drawing covariates is done to make the model fit to attain significant results.

Discussion

In today's digital world, the media industry is heavily dependent on nano-content, and the majority of the community prefers this format for gathering information, daily learning needs, entertainment, and educational purposes. Research suggests that concise learning material is more effective than detailed content. It takes only two to three minutes for the learners to build an understanding of complex

concepts or formulas. Nano learning practices can be used as a strategy, technique, and method to supplement the daily classroom teaching and learning practices. As per the literature, it is found that nano learning practices are related to the delivery of content into small bits and units based on Learning Objectives, Chunking Information, Effective Assessment, Incorporating Visuals and Multimedia, and Timely Feedback for the learners. Nano learning practices help to make the tasks easily understandable with the integration of videos, audio, and infographics etc. One will want to learn more when they find the task easy to understand. The present research was an attempt to frame a tool to measure the nano learning practices at the university level. After getting into literature, some key factors were identified, and items were prepared accordingly.

Conclusion

In this study Nano Learning Practices instrument was developed after a detailed review of the literature on nano learning practices and identified three distinct dimensions through exploratory factor analysis. The confirmation is done through significant factor loadings. The initial draft of the developed instrument consisted of 27 items. The final instrument contained 25 items after the analysis. Overall reliability for the scale (as determined by Cronbach's Alpha) is 0.878. considered high. The alpha values for subscales range between 0.916 to 0.973. Convergent validity is considered as AVE, values required for it must be > 0.5 . All identified values are > 0.5 . Hence, the instrument was approved to be valid. Analysis for reliability was also executed. These values indicated that all factors are > 0.6 , which shows the instrument is reliable. Results of the analysis found that the developed instrument is reliable and valid. The categorized sub-factors of the items revealed that nano-learning practices are implemented in various ways in teaching and learning content. The Nano Learning Practices Scale (NLPS) is a valuable instrument for researchers and educators for measuring the nano learning practices in academic settings.

Recommendations

The present research provides the following recommendations for further investigation:

1. This study may provide a foundation to explore the concept of nano learning and its application in different academic contexts.
2. This study may help educators, policymakers, and instructional designers to implement these practices practically in the field of education.
3. Investigating the underlying setting objectives, chunking information, effective assessment, incorporating visuals and multimedia, and timely feedback to assess the nano learning practices may provide deeper insights into how these practices can be planned and implemented in academic settings.
4. The Nano Learning Practices Scale may be a stepping stone for future researchers to apply this instrument with the addition of sub-factors to assess the nano learning practices.
5. This study may provide research directions for future researchers to explore the relationship between nano learning practices and students' learning outcomes.

References

- Aburizaizah, S. J., & Albaiz, T. A. (2021, September). Review of the use and impact of nano-learning in education. In *4th International Conference on Research in Education* (Vol. 4, No. 1, pp. 83-93).
- Baughman, B., Digman, C., & Ramadan, J. (2023). Nanotechnology: Nano Measures with Giga Implications for Education. *Current Academic Studies in Technology and Education*, 74-104.
- Bakker, A., & Van Eerde, D. (2015). An introduction to design-based research with an example from statistics education. *Approaches to qualitative research in mathematics education: Examples of methodology and methods*, 11(2), 429-466.
- Briggs, S. R., & Cheek, J. M. (1986). The role of factor analysis in the development and evaluation of personality scales. *Journal of Personality*, 54(1), 106-148.
- Cabrero, R. S., & Román, Ó. C. (2018). Psycho pedagogical predecessors of connectivism as a new paradigm of learning. *International Journal of Educational Excellence*, 4(2), 29-45.
- Cua, K. O., McKone, K. E., & Schroeder, R. G. (2001). Relationships between the implementation of TQM, JIT, and TPM and manufacturing performance. *Journal of Operations Management*, 19(6), 675-694.
- Field, A. (2024). *Discovering statistics using IBM SPSS statistics*. Sage publications limited.

Development and Validation of a Nano Learning Practices Scale (NLPS).....Kanwal & Farooq

- Fornell, C., & Larcker, D. F. (1981). Structural equation models with unobservable variables and measurement error: Algebra and statistics.
- Gramming, A. C. K., Ejemyr, E., & Thunell, E. (2019). Implementing nano-learning in the law firm. *Legal Information Management*, 19(4), 241-246.
- Hudovernik, E. (2021). How Nano Learning Could Affect the Future of Education, Education World. Retrieved from <https://www.educationworld.com/teachers/how-nano-learning-could-affect-future-education>.
- Henson, R. K., & Roberts, J. K. (2006). Use of exploratory factor analysis in published research: Common errors and some comments on improved practice. *Educational and Psychological measurement*, 66(3), 393-416.
- Henseler, J., Ringle, C. M., & Sinkovics, R. R. (2009). The use of partial least squares path modeling in international marketing. In *New challenges to international marketing* (pp. 277-319). Emerald Group Publishing Limited.
- Hinton, P. R. (2004). *Statistics Explained: A Guide for Social Science Students* (1st ed.) Routledge.
- Kävrestad, J., & Nohlberg, M. (2019). Using context based micro training to develop OER for the benefit of all. In *Proceedings of the 15th International Symposium on Open Collaboration* (pp. 1-10).
- Marks, J. (2021). Let's Be Reasonable: A Conservative Case for Liberal Education.
- Mayer, R. E. (2002). Rote versus meaningful learning. *Theory into Practice*, 41(3), 226-232.
- Merriënboer, J. J. G. van, & Sweller, J. (2005). Cognitive Load Theory and Complex Learning: Recent Developments and Future Directions. *Educational Psychology Review*, 17(2), 147-177.
- Railean, E. A. (2016). Digital screens and issues of multiliteracies' learning. In *User interface design of digital textbooks: How screens affect learning* (pp. 43-57). Singapore: Springer Singapore.
- Sukmojati, E., Putra, R. D., Nazira, A., Nafiah, S. U., Saturnus, M., Dewi, N. L. P. M., & Ummah, H. (2025). Nano Learning in Education: Concept and Best Practice.
- Straub, D., Gefen, D., & Boudreau, M.C. (2004). Validating instruments in MIS research. *Communications of the AIS*, 13(9), 467-520. <https://doi.org/10.17705/1CAIS.01323>
- Sweller, J., van Merriënboer, J. J. G., & Paas, F. G. W. C. (1998). Cognitive architecture and instructional design. *Educational Psychology Review*, 10(22), 251-296.
- Tabachnick, B. G., Fidell, L. S., & Ullman, J. B. (2007). *Using multivariate statistics* (Vol. 5, pp. 7). Boston, MA: pearson.